

Fingerstock Gasketing Beryllium Copper and Stainless Steel (5200 Series)

Product Summary

Our fingerstock gasketing made of Beryllium Copper is ideal for repeated opening and closing applications where high attenuation performance and mechanical strength is required.

Beryllium copper's electrical properties provide shielding effectiveness over an extremely broad frequency range. Mechanically, Beryllium Copper yields a high deflection range, with low compression set.

Beryllium Copper, alloy 25, is used for maximum spring properties of strength and fatigue resistance. A variety of fingerstock is also available in stainless steel. Contact our factory for profiles and availability.

Product Application

Fingerstock is used in a wide variety of applications, usually where repeated opening and closing usually of an enclosure or cover for an enclosure that is required to meet EMC specifications.

Some common features of MAJR's fingerstock is: RoHS Compliant, high EMI/RFI attenuation levels, a wide variety of plating and finishings, a wide range of configurations available as strips or on rolls for select configurations, and a high temperature tolerance.



Product Technical Data

5200 Series Track

5200-06D37-XX

OMNI

Compression Force - Single Contact

	25% Compression (0.098")	50% Compression (0.065")
Standard	.2 lbs	.4 lbs

Mounting Pad Material: Brass. Finish: Bright.
Other finishes are also available.

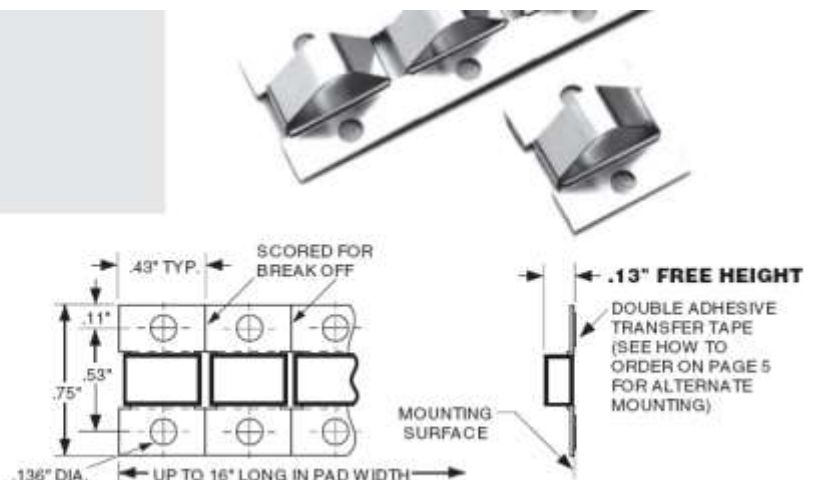

Fingerstock Gasketing Beryllium Copper and Stainless Steel (5200 Series) (Cont.)

5210 Series Track Mounting



5210-01A32-XX

SYMMETRICAL

Compression Force

	25% Compression (0.075")	50% Compression (0.050")
Standard	9.1 lbs/ft	18.1 lbs/ft

Note: For use with Track TR52.

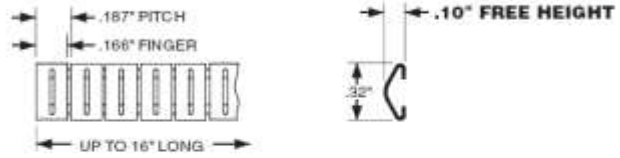

Consult factory for the availability of longer lengths.

5210-01D60-XX

SYMMETRICAL

Compression Force

	25% Compression (0.165")	50% Compression (0.110")
Standard	11 lbs/ft	27 lbs/ft
TF Style	4.0 lbs/ft	10 lbs/ft

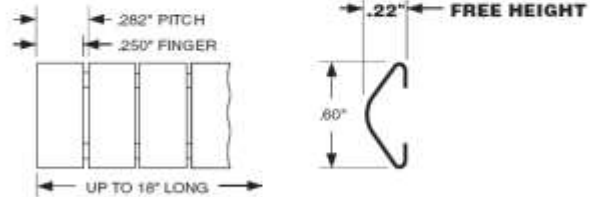

See page 5 for rivets and end stops if required.

5220 Series Snap-on Mounting



5220-02C32-XX

SYMMETRICAL

GAP RANGE UP TO .06"

Compression Force

	25% Compression (0.053")	50% Compression (0.035")
Standard	2.7 lbs/ft	14 lbs/ft
TF Style	2.5 lbs/ft	6.5 lbs/ft

APPLICATION DATA

Note:
1. *Actual length determined by finger pattern.

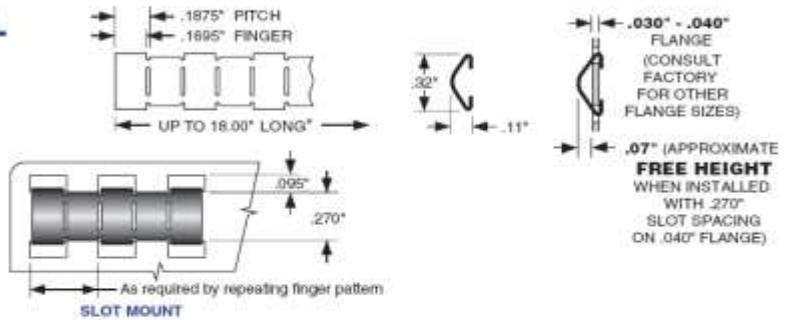

5220-03C32-XX

SYMMETRICAL

GAP RANGE UP TO .06"

Compression Force

	25% Compression (0.053")	50% Compression (0.035")
Standard	4.1 lbs/ft	14 lbs/ft
TF Style	1.1 lbs/ft	1.3 lbs/ft

APPLICATION DATA

Note:
1. *Actual length determined by finger pattern.

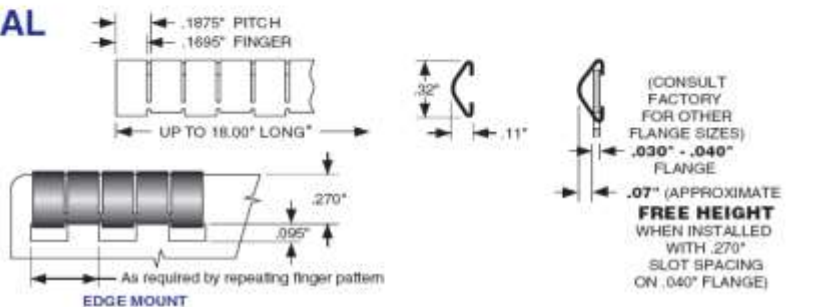

Fingerstock Gasketing Beryllium Copper and Stainless Steel (5200 Series) (Cont.)



5220-05D37-XX SYMMETRICAL

GAP RANGE UP TO .075"

Standard

APPLICATION DATA

Notes:

1. Length of slot as required by number of fingers.
2. Spacing determined by attenuation requirements.

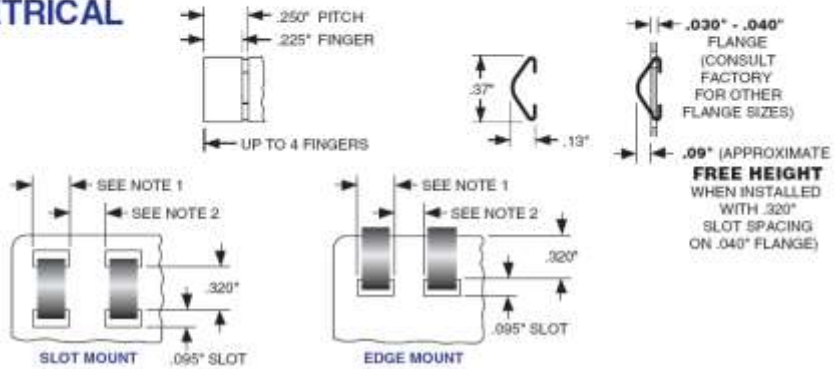

5220-06D37-XX SYMMETRICAL

GAP RANGE UP TO .075"

Compression Force

	25% Compression (0.068")	50% Compression (0.045")
Standard	1.3 lbs/ft	6.9 lbs/ft

APPLICATION DATA

Note:

1. *Actual length determined by finger pattern.

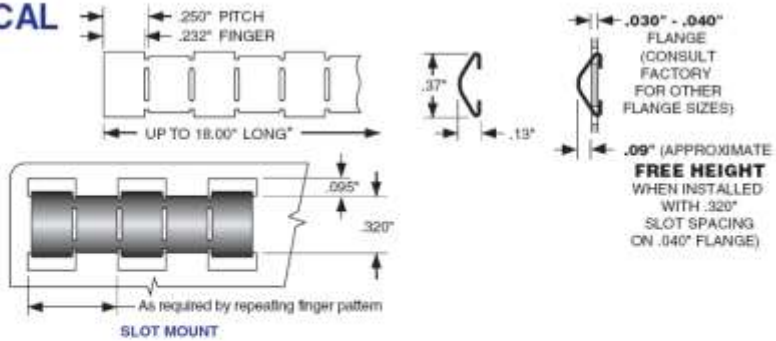

5220-07D37-XX SYMMETRICAL

GAP RANGE UP TO .075"

Compression Force

	25% Compression (0.068")	50% Compression (0.045")
Standard	1.5 lbs/ft	4.1 lbs/ft

APPLICATION DATA

Note:

1. *Actual length determined by finger pattern.

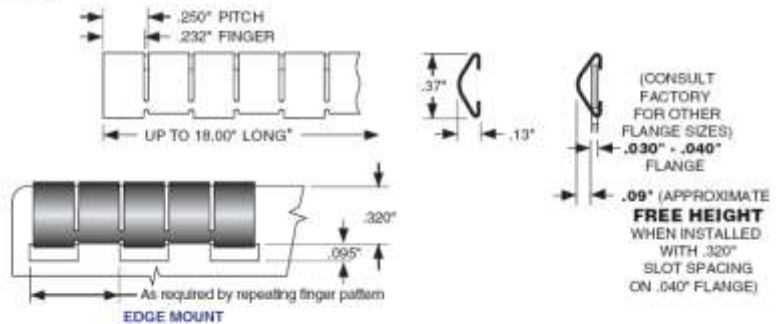

5220-08G60-XX SYMMETRICAL

GAP RANGE UP TO .113"

Standard
"TF" Style

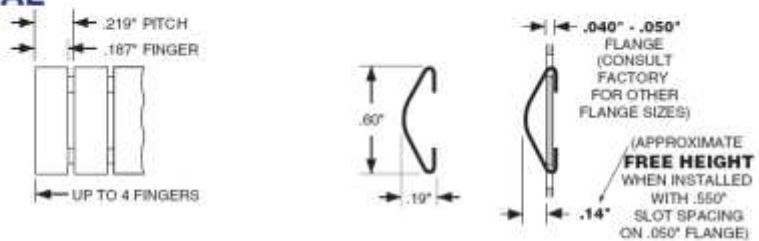

Fingerstock Gasketing Beryllium Copper and Stainless Steel (5200 Series) (Cont.)



5220-13I36-XX SOFT NO-SNAG FINGERS

GAP RANGE UP TO .068"

Standard

APPLICATION DATA

Notes:

1. Length of slot as required by number of fingers.
2. Spacing determined by attenuation requirements.

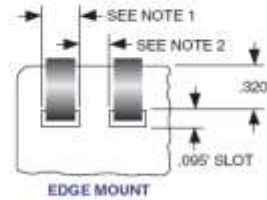
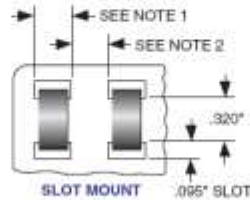
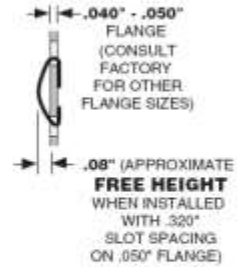
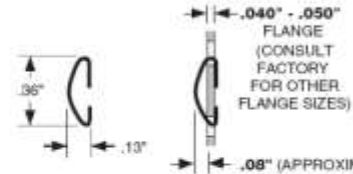
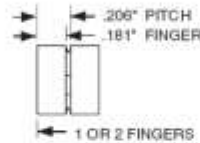

5230-01C35-XX SOFT NO-SNAG FINGERS

Compression Force

	25% Compression (0.083")	50% Compression (0.055")
Standard	25 lbs/ft	69 lbs/ft
"TF" Style	6 lbs/ft	23 lbs/ft

Note: Also available with optional double adhesive transfer tape.

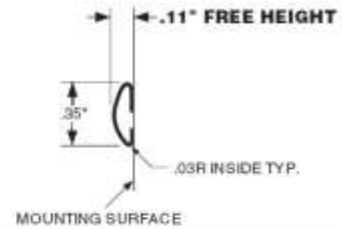
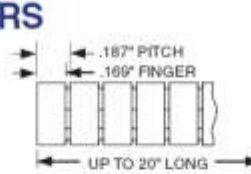

5230-02B28-XX LOW PROFILE NO-SNAG

Compression Force

	25% Compression (0.045")	50% Compression (0.030")
Standard	5.5 lbs/ft	20.4 lbs/ft

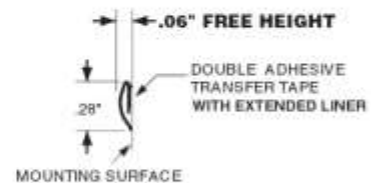
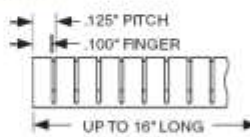

5230-03B32-XX LOW PROFILE NO-SNAG

Compression Force

	25% Compression (0.060")	50% Compression (0.040")
Standard	6.8 lbs/ft	17 lbs/ft

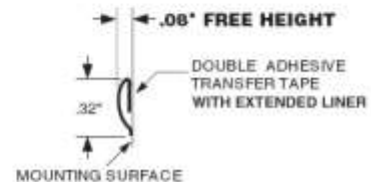
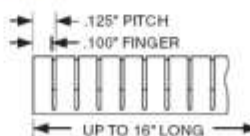

Fingerstock Gasketing Beryllium Copper and Stainless Steel (5200 Series) (Cont.)



5230-07B45-XX HOOK & STICK-ON LOW PROFILE NO-SNAG

Compression Force

25% Compression (0.045")	50% Compression (0.030")
10 lbs/ft	19 lbs/ft
6.4 lbs/ft	17 lbs/ft

Note: Also available in Stainless Steel

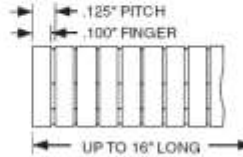

5230-08B60-XX HOOK & STICK-ON LOW PROFILE NO-SNAG

Compression Force

25% Compression (0.068")	50% Compression (0.045")
8.7 lbs/ft	17.3 lbs/ft
5.8 lbs/ft	9.0 lbs/ft

Note: Also available in Stainless Steel

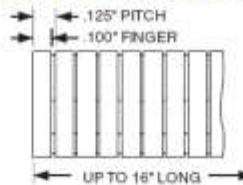

5230-09B60-XX HOOK & STICK-ON LOW PROFILE NO-SNAG

Compression Force

25% Compression (0.105")	50% Compression (0.070")
19 lbs/ft	35 lbs/ft
6.8 lbs/ft	14 lbs/ft

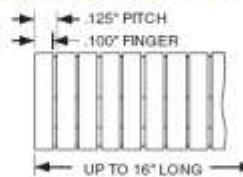

5230-10J21-XX SOFT NO-SNAG FINGERS

Compression Force

	25% Compression (0.060")	50% Compression (0.040")
Standard	11 lbs/ft	34 lbs/ft

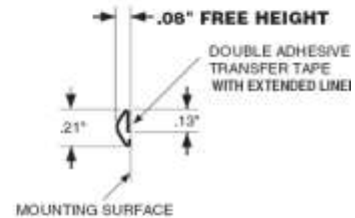
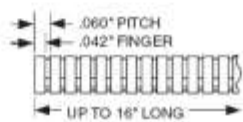

5230-11C21-XX SOFT NO-SNAG FINGERS

Compression Force

	25% Compression (0.090")	50% Compression (0.060")
Standard	12 lbs/ft	24 lbs/ft

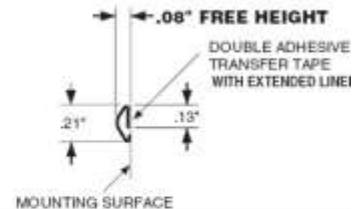
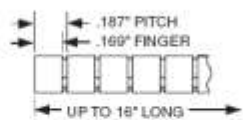

5230-12C28-XX SOFT FINGERS

Compression Force

	25% Compression (0.083")	50% Compression (0.055")
Standard	15 lbs/ft	32 lbs/ft

Note: Also available in 25 ft. rolls.

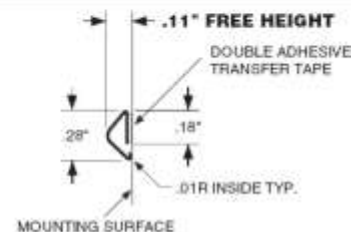
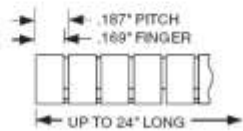

Fingerstock Gasketing Beryllium Copper and Stainless Steel (5200 Series) (Cont.)

5230 Series Stick-on Mounting



5230-13C32-XX SOFT NO-SNAG FINGERS

Compression Force

	25% Compression (0.083")	50% Compression (0.055")
Standard	14 lbs/ft	26 lbs/ft

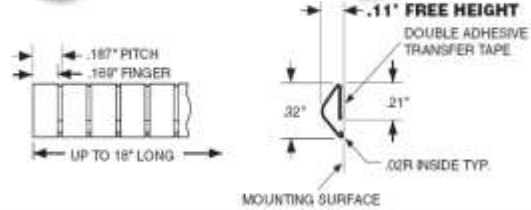

5230-14D37-XX SOFT NO-SNAG FINGERS

Compression Force

	25% Compression (0.098")	50% Compression (0.065")
Standard	10 lbs/ft	21 lbs/ft

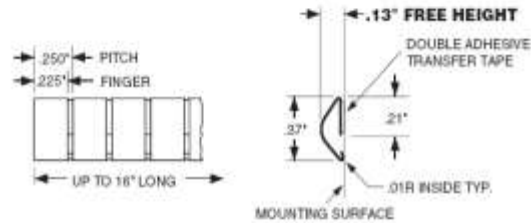

5230-15D50-XX SOFT NO-SNAG FINGERS

Compression Force

	25% Compression (0.098")	50% Compression (0.065")
Standard	10 lbs/ft	21 lbs/ft

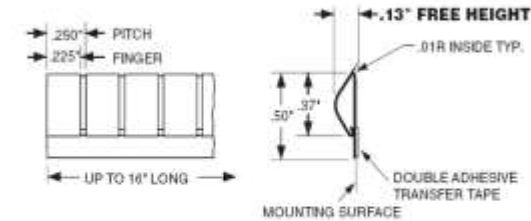

5230-16E60-XX SOFT NO-SNAG FINGERS

Compression Force

	25% Compression (0.165")	50% Compression (0.110")
Standard	10 lbs/ft 2.0 lbs/ft	20 lbs/ft 7.2 lbs/ft

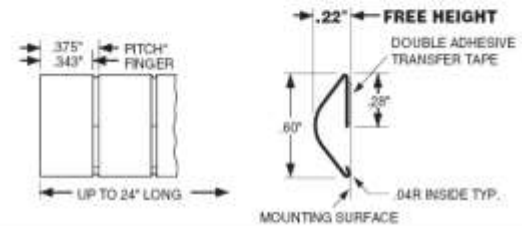

5230-17E80-XX SOFT NO-SNAG FINGERS

Compression Force

	25% Compression (0.240")	50% Compression (0.160")
Standard	7 lbs/ft	17 lbs/ft

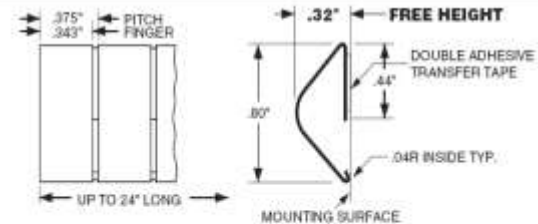

5230-18F110-XX SOFT NO-SNAG FINGERS

Compression Force

	25% Compression (0.300")	50% Compression (0.200")
Standard	12 lbs/ft	24 lbs/ft

Note: Up to 18" long.

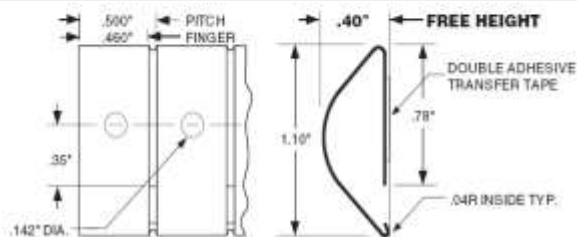

Fingerstock Gasketing Beryllium Copper and Stainless Steel (5200 Series) (Cont.)

5230 Series Stick-on Mounting



5230-21E60-XX NO-SNAG FINGERS

Compression Force

	25% Compression (0.165")	50% Compression (0.110")
Standard	13 lbs/ft	32 lbs/ft

Note: Also available in .187" Pitch.

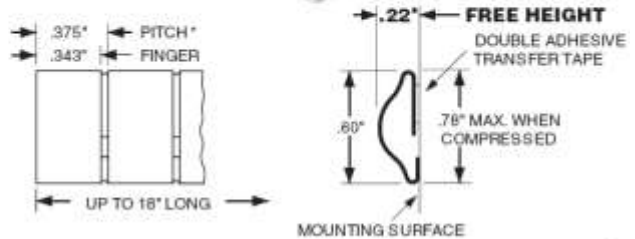

5230-24T95-XX TWISTED CONTACTS

Compression Force

	25% Compression (0.023")	50% Compression (0.015")
Standard	5.8 lbs/ft	35 lbs/ft
"TF" Style	4.9 lbs/ft	19 lbs/ft

Notes: Also available in 25 ft. rolls.

(SS) Also available in Stainless Steel

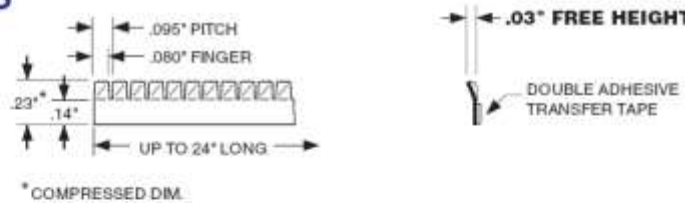

5230-25-95T90-XX TWISTED CONTACTS

Compression Force

	25% Compression (0.023")	50% Compression (0.015")
Standard	12 lbs/ft	51 lbs/ft
"TF" Style	2.5 lbs/ft	10 lbs/ft

Note: (SS) Also available in Stainless Steel

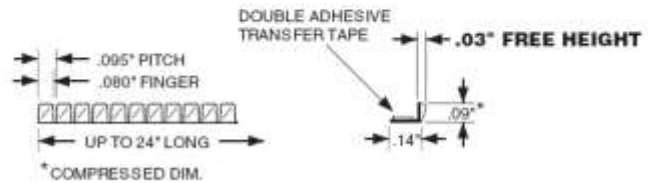

5230-26-165T-XX TWISTED CONTACTS

Compression Force

	25% Compression (0.053")	50% Compression (0.035")
Standard	18 lbs/ft	36 lbs/ft
"TF" Style	4.2 lbs/ft	11 lbs/ft

Notes: Also available in 25 ft. rolls.

(SS) Also available in Stainless Steel

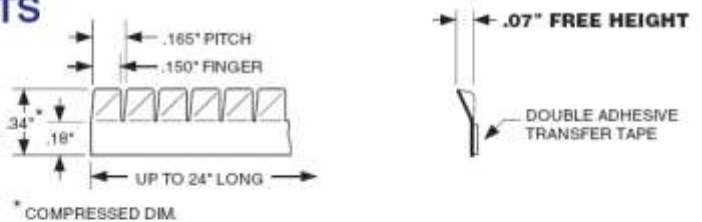

5230-27-165T-XX TWISTED CONTACTS

Compression Force

	25% Compression (0.053")	50% Compression (0.035")
Standard	18 lbs/ft	36 lbs/ft
"TF" Style	4.2 lbs/ft	11 lbs/ft

Note: (SS) Also available in Stainless Steel

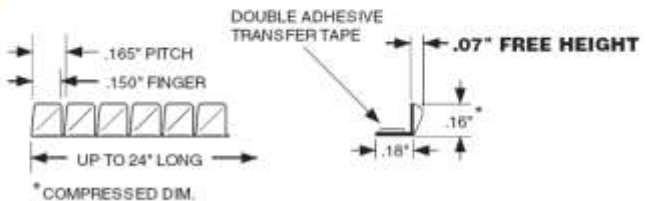

Fingerstock Gasketing Beryllium Copper and Stainless Steel (5200 Series) (Cont.)

5240 Series Clip-on Mounting



5240-01D70-XX

PERPENDICULAR CONTACT

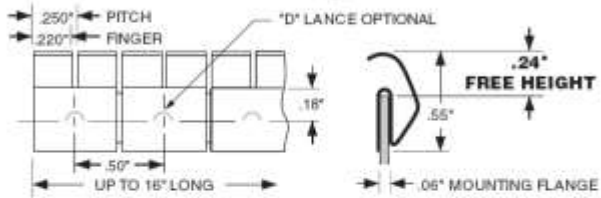

5240-02D40-XX

LOW PROFILE

Compression Force

	25% Compression (0.045")	50% Compression (0.030")
Standard	15 lbs/ft	83 lbs/ft
"TF" Style	6.6 lbs/ft	30 lbs/ft

Notes: Optional lance available as shown.
 (SS) Also available in Stainless Steel

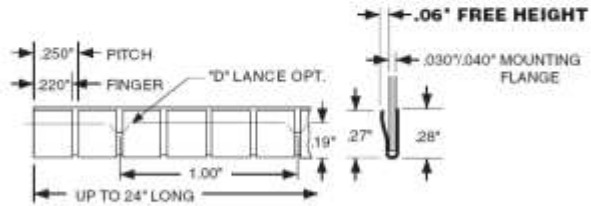

5240-07L09-XX

CYLINDRICAL RADIUS

Compression Force

	25% Compression (0.075")	50% Compression (0.050")
	14 lbs/ft	49 lbs/ft
	4.5 lbs/ft	22 lbs/ft

Note: Non-standard lance location(s).

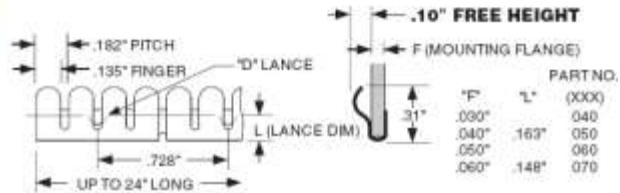

5240-09C03-XX

CYLINDRICAL RADIUS

Compression Force

	25% Compression (0.105")	50% Compression (0.070")
	18 lbs/ft	N/A

* Consult factory for performance data.

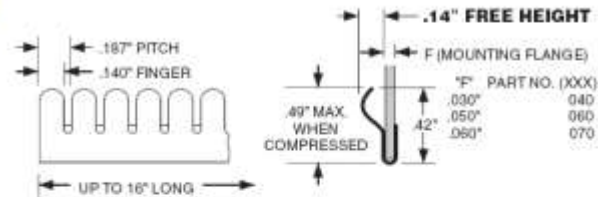

5240-10C70-XX

CYLINDRICAL RADIUS

Compression Force

	25% Compression (0.120")	50% Compression (0.080")
Standard	11 lbs/ft	69 lbs/ft
"TF" Style	6.9 lbs/ft	21 lbs/ft

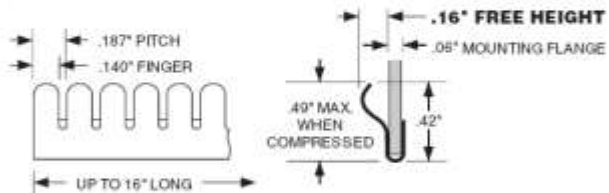

5240-12E90-XX

STRIP GASKETS

Compression Force

	25% Compression (0.195")	50% Compression (0.130")
Standard	17 lbs/ft	43 lbs/ft

Note: Drawing shown at reduced scale.

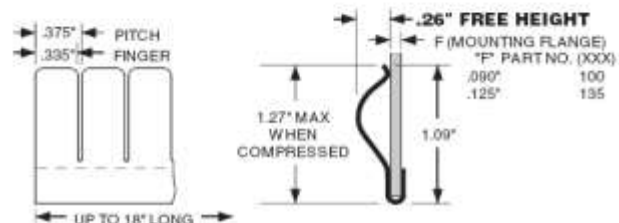

Fingerstock Gasketing Beryllium Copper and Stainless Steel (5200 Series) (Cont.)



5240-14D27-XX REVERSE BEND CONTACTS

Compression Force

	25% Compression (0.203")	50% Compression (0.135")
Standard	5 lbs/ft	15 lbs/ft

Note: Non-standard lance location(s). Also available in 25 ft. rolls. Scores for break off between 1/2" increments optional.

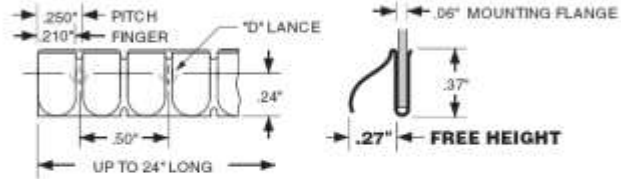

5240-17T16-XX TWISTED CONTACTS

Compression Force

	25% Compression (0.053")	50% Compression (0.035")
Standard	10 lbs/ft	22 lbs/ft

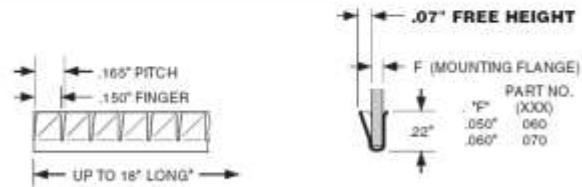

5240-18T95-XX TWISTED CONTACTS

Compression Force

	25% Compression (0.023")	50% Compression (0.015")
Standard	32 lbs/ft	48 lbs/ft

Note: Optional lance available as shown.

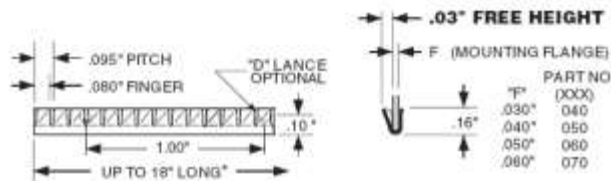

5240-19D42-XX NO-SNAG FINGERS

Compression Force

	25% Compression (0.090")	50% Compression (0.060")
Standard	29 lbs/ft	69 lbs/ft
"TF" Style	15 lbs/ft	35 lbs/ft

* Note: Also available in .125" Pitch. (125M42CXXX)

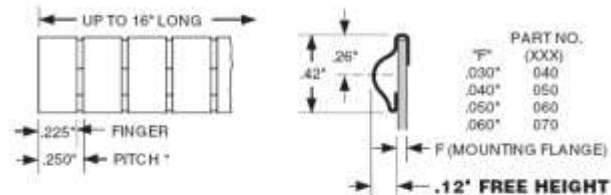

5240-19070-XX CYLINDRICAL RADIUS

Compression Force

	25% Compression (0.158")	50% Compression (0.105")
Standard	3.5 lbs/ft	16 lbs/ft

* Note: Non-standard lance location(s).

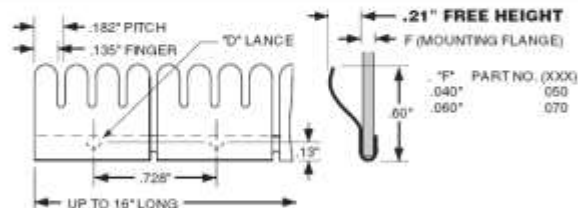

5240-20E70-XX SOFT NO-SNAG FINGERS

Compression Force

	25% Compression (0.165")	50% Compression (0.110")
Standard	18 lbs/ft	36 lbs/ft

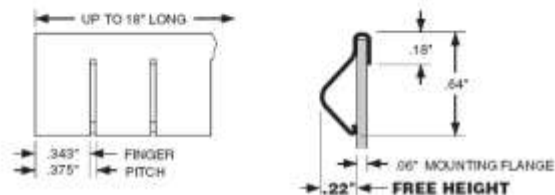

Fingerstock Gasketing Beryllium Copper and Stainless Steel (5200 Series) (Cont.)

5250 Series Special Mounting



5250-01R60-XX REVERSE BEND SPHERICAL

Compression Force

	25% Compression (0.675")	50% Compression (0.045")
Standard	7 lbs/ft	10 lbs/ft

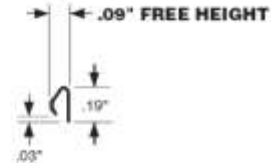
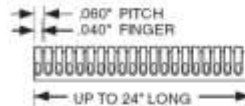

5250-02R75-XX REVERSE BEND SPHERICAL

Compression Force

	25% Compression (0.120")	50% Compression (0.080")
Standard	15 lbs/ft	47 lbs/ft

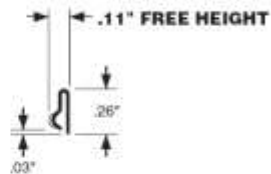
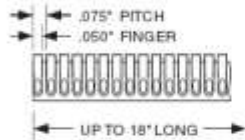

5250-03R93-XX REVERSE BEND SPHERICAL

Compression Force

	25% Compression (0.059")	50% Compression (0.035")
Standard	18 lbs/ft	41 lbs/ft

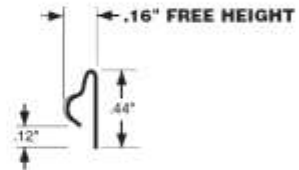
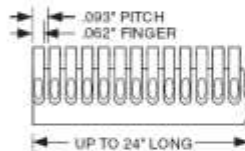

5250-04R60-XX REVERSE BEND CONTACTS

Compression Force

	25% Compression (0.150")	50% Compression (0.100")
Standard	18 lbs/ft	160 lbs/ft
"TF" Style	7 lbs/ft	27 lbs/ft

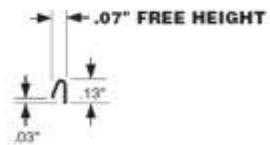

5250-09R34-XX REVERSE BEND CONTACTS

Compression Force

	25% Compression (0.150")	50% Compression (0.100")
Standard	18 lbs/ft	160 lbs/ft
"TF" Style	7 lbs/ft	27 lbs/ft

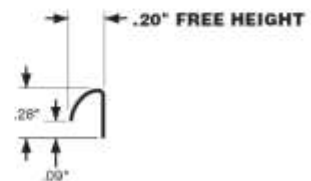
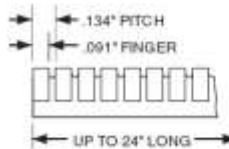

5250-10R87-XX REVERSE BEND CONTACTS

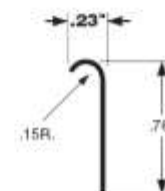
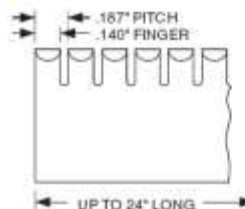

Fingerstock Gasketing Beryllium Copper and Stainless Steel (5200 Series) (Cont.)

5250 Series Special Mounting



5250-12R34-XX REVERSE BEND CONTACTS

Compression Force

	25% Compression (0.330")	50% Compression (0.220")
Standard	16 lbs/ft	46 lbs/ft

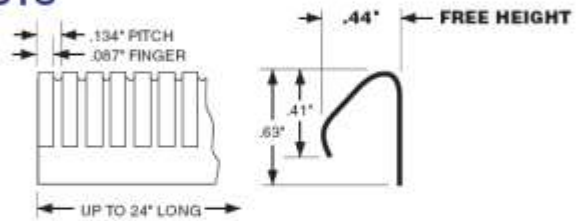

5240-20E70-XX SOFT NO-SNAG FINGERS

Compression Force

	25% Compression (0.165")	50% Compression (0.110")
Standard	18 lbs/ft	36 lbs/ft

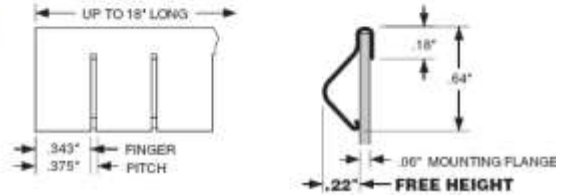

5250-01S60-XX SPHERICAL RADIUS

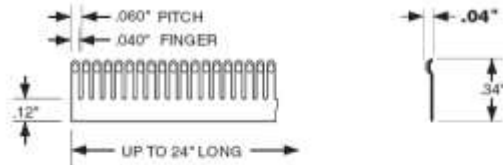

5250-03S75-XX SPHERICAL RADIUS

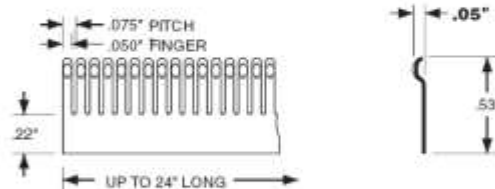

5250-09S37-XX CYLINDRICAL RADIUS

Compression Force

	25% Compression (0.165")	50% Compression (0.110")
Standard	18 lbs/ft	48 lbs/ft

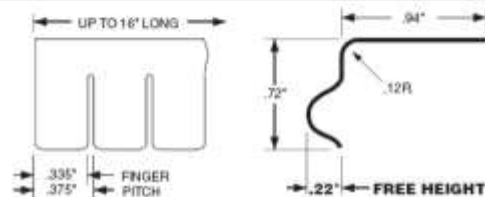

ISO-9001:2000 Certified - Veteran Owned Manufacturer

MAJR Products Corporation
780 South Street
Saegertown, PA 16433
PH: (814) 763-3211 FX: (814) 763-2952
www.majr.com email: sales@majr.com