

Installation Guide for Surface Mounted Honeycomb Waveguide Panel (3031 series)

On Duct Surface Mount Installation

1. Utilize the 0.5-inch-wide panel flanges and pre-installed EMI gasket to position the panel to the duct or wall aperture.
2. Mount the panel with bolts or screws through the duct flange and into the wall via the through holes located on the panel frame.
3. Ensure pre-installed EMI gasket makes continuous electrical contact to the flanged duct, RF foil or metal wall around the full perimeter of the panel to wall interface for optimal shielding performance.

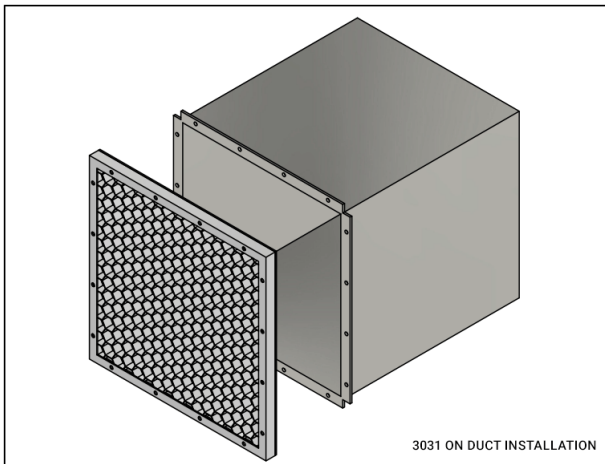

“Between Duct” Surface Mount Installation

1. Separate ductwork and flange outward 90 degrees to no less than 0.5 inches on all sides.
2. Mount with pre-installed EMI gaskets between the duct flanges utilizing bolts and the panel through holes to secure.
3. Ensure continuous duct to EMI gasket contact on both sides of the panel to the duct flange interface is required for optimal shielding performance.

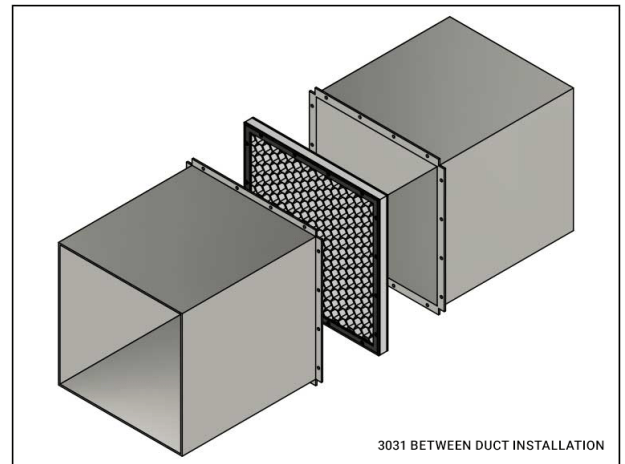

Installation Notes

Duct Flanges for Mounting

Surface Mounted Panels have a 0.5-inch-wide C channel frame around the entire panel making its outer perimeter roughly 1.0 inch larger than the air duct it’s designed for. To accommodate this additional frame width MAJR recommends the air duct is bent to create mounting flanges or surfaces at a 90 deg. angle on all sides as seen in example# 1 & 2 above. These flanges should have a minimum width of 0.5-inches to accommodate and match up with the waveguide panel flange/frame and pre-installed EMI gasket.

Multi-panel Installation for Large Duct Openings

Some air ducts or openings are too large for a single waveguide panel. In these cases, MAJR will manufacture panels in 2 or more sections and recommends a T-Bar style extrusion or “L” angle be installed to aid in mounting.

T-Bar Extrusion

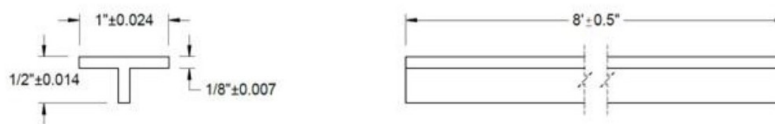

This bar should be the same or similar material to the panel. Bars will need to be cut to length and welded in place at the center or appropriate location of the duct opening to enable mounting of multiple panels. Waveguide panels should be mounted as instructed above utilizing panel frame/flange through holes and EMI gasket to ensure good electrical contact around the entire panel frame to duct interface.